

## MOTORCYCLE STORAGE PLUS

### BASE INSTRUCTIONS

Flat and firm base. Recommended: concrete, tarmac or paving flags.  
 Min. distance from walls/ shrubbery: 1000mm.  
 Min. base size (WxDxH) 3790mm x 1730mm x 50mm.

Drill through the four holes in the base of the unit using 6mm dia masonry drill to a depth of 70mm. Screw in the anchor fixings. (These have a self cutting thread). If not anchoring the unit, fit the self seal plugs BEFORE BUILDING to seal the fixing holes from underneath.

### LEVELING THE UNIT

Correctly level the constructed unit using the shims (ZCOMPPLAS) provided prior to fixing the unit to the ground. Slide the packing pieces under the corners of the unit base as required until an equal gap has been achieved around the door allowing for its smooth operation and alignment.

Please note product must be bolted down to comply with LPS1175.

### TOOLS REQUIRED

Power driver POSI-DRIV screwdriver, 6mm dia. masonry drill and a 13mm socket spanner.



Warning: panels weigh over 20Kg  
 Beware of manual handling

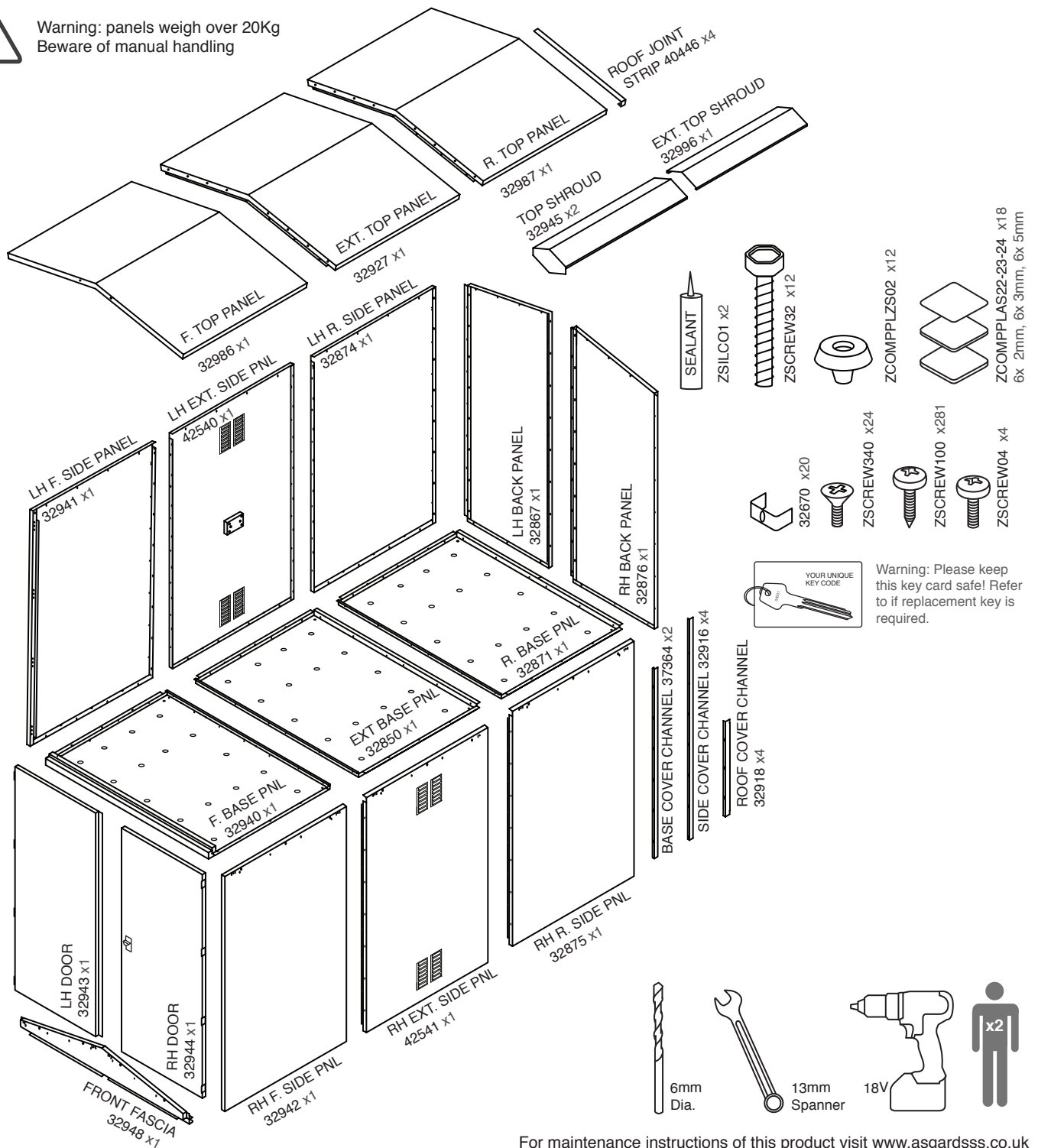

PLEASE NOTE ALL SCREWS ARE FIXED FROM THE INSIDE

1

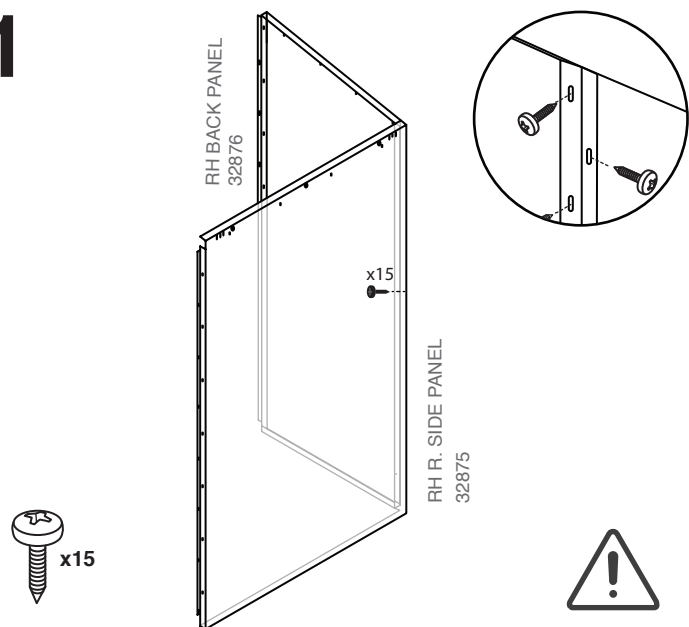

2

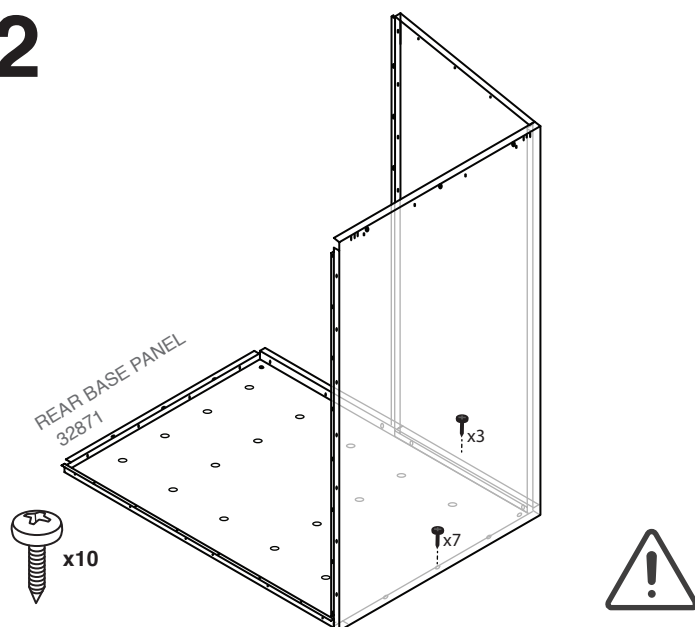

3

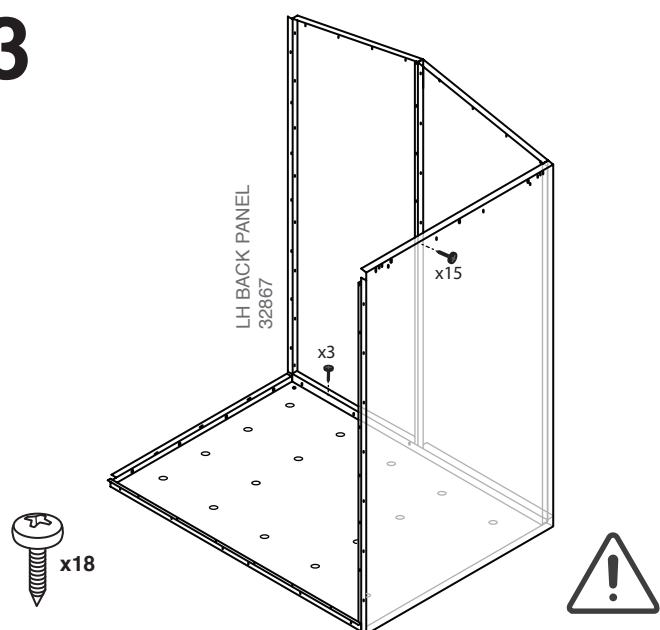

4

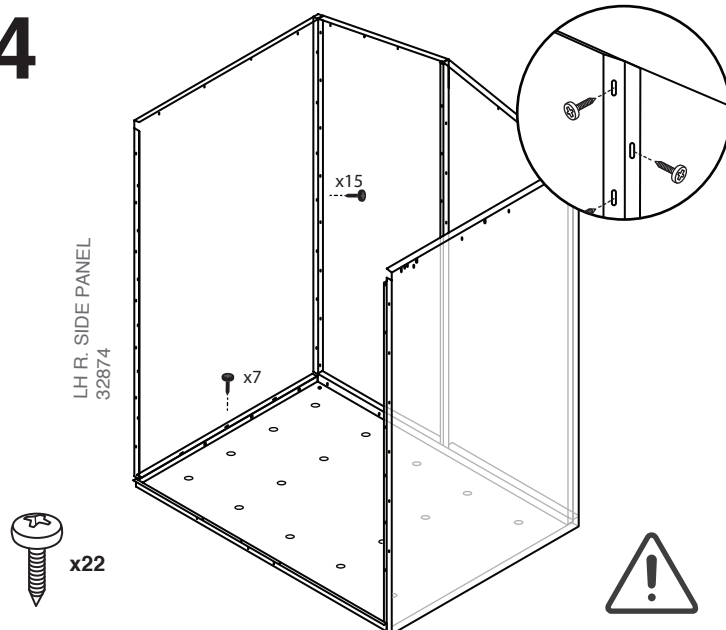

5

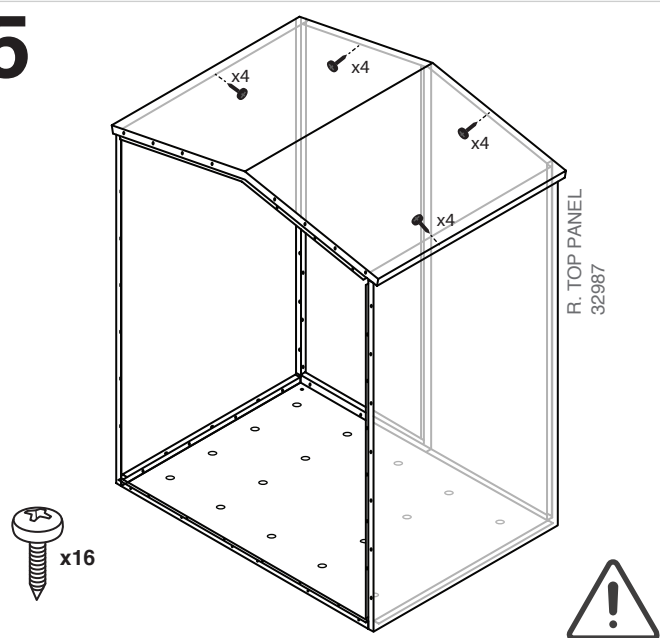

6

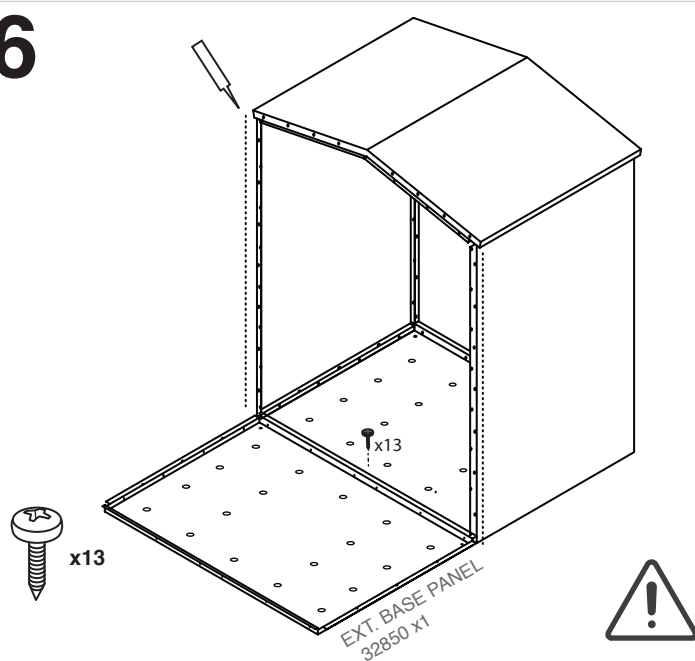

7

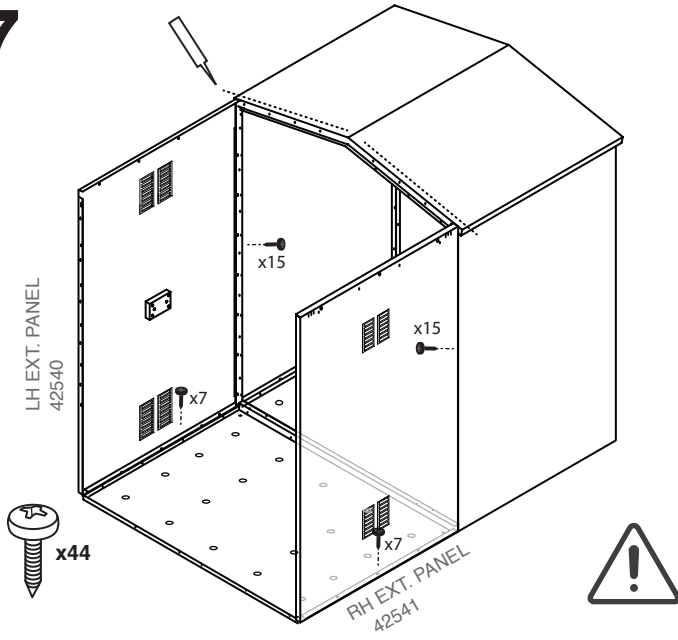

8

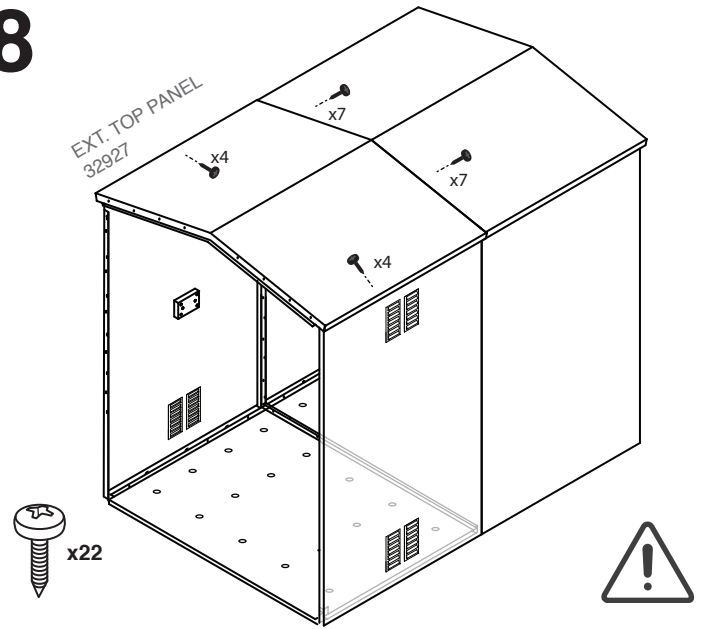

9

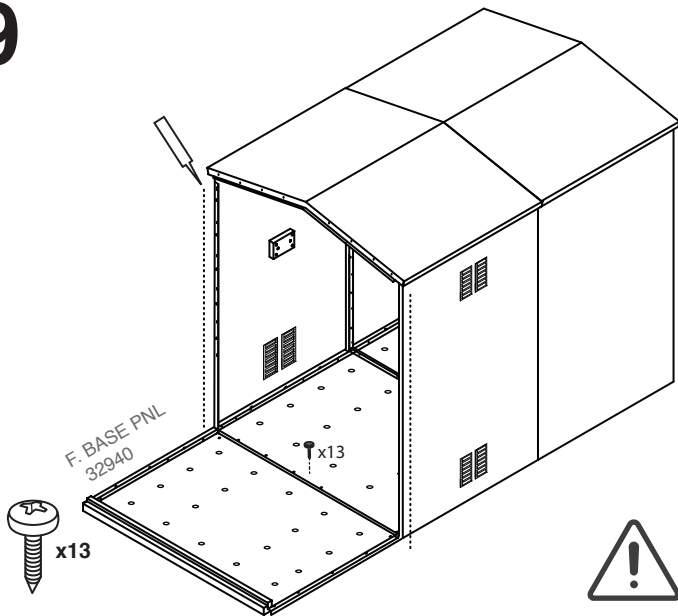

10

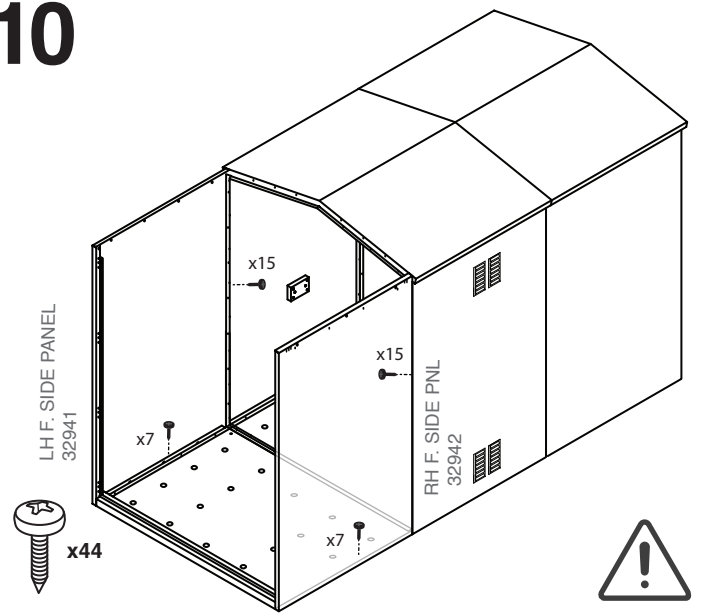

11

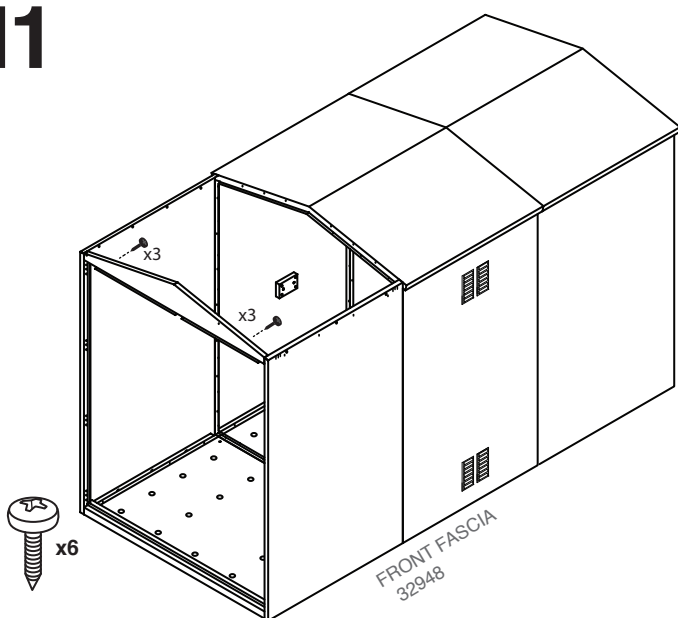

12

