

GAS BOTTLE STORAGE (SML)

BASE INSTRUCTIONS

Flat and firm base. Recommended: concrete, tarmac or paving flags.
Min. base size (WxDxH) 850mm x 525mm x 50mm.

Please note this product is to fit 2x 19KG gas bottles. Calor approved.

LEVELING THE UNIT

Correctly level the constructed unit using the shims (ZCOMPPLAS) provided prior to fixing the unit to the ground. Slide the packing pieces under the corners of the unit base as required until an equal gap has been achieved around the door allowing for its smooth operation and alignment.

Drill through the four holes in the base of the unit using 6mm dia masonry drill to a depth of 70mm. Screw in the anchor fixings. (These have a self cutting thread).

TOOLS REQUIRED

Power driver POSI-DRIV screwdriver, 6mm dia. masonry drill and a 10mm socket or spanner.

DOOR HANDLING

The door handling is always delivered hung from the right. Doors can be reversed on site.

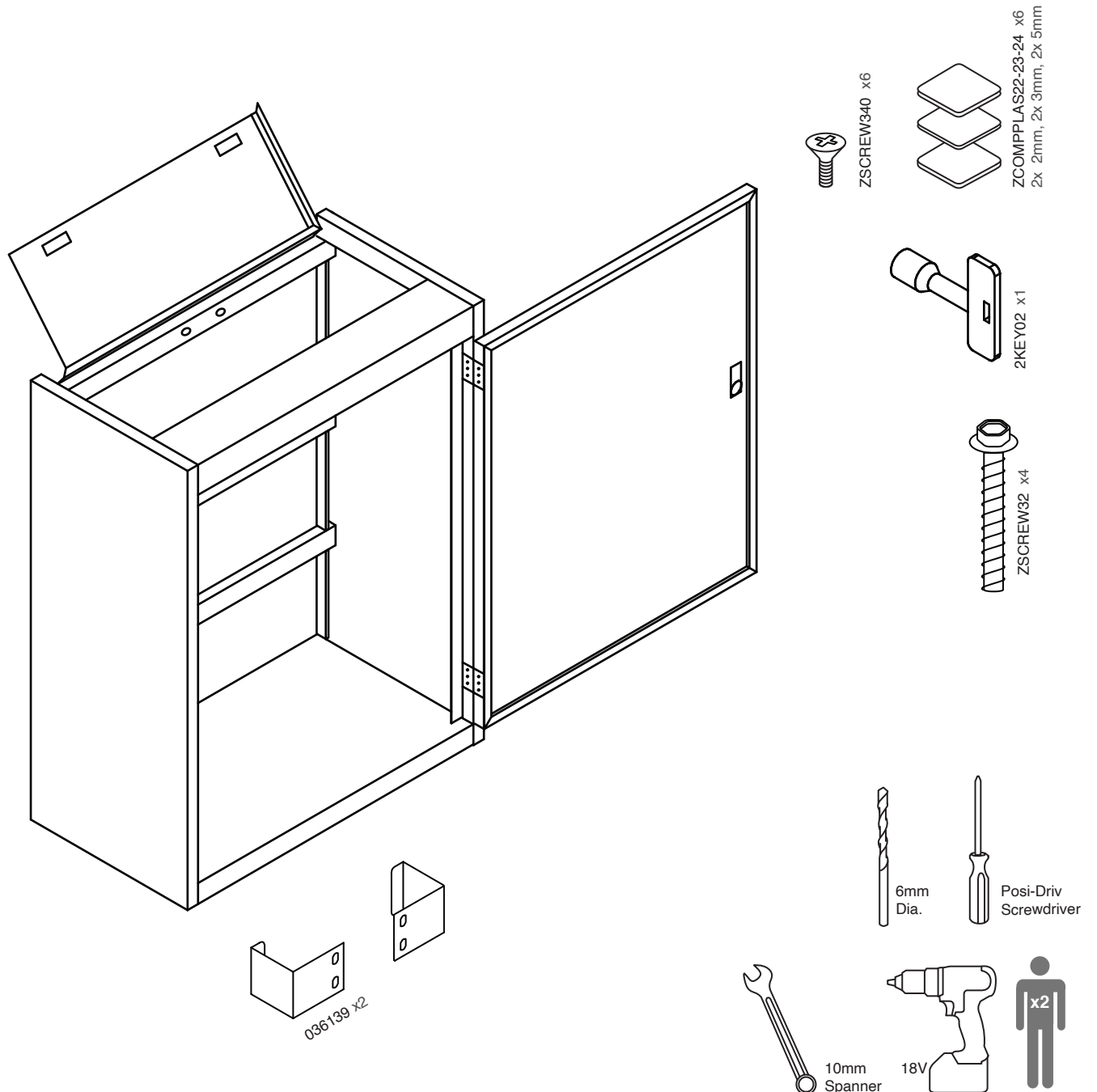

1

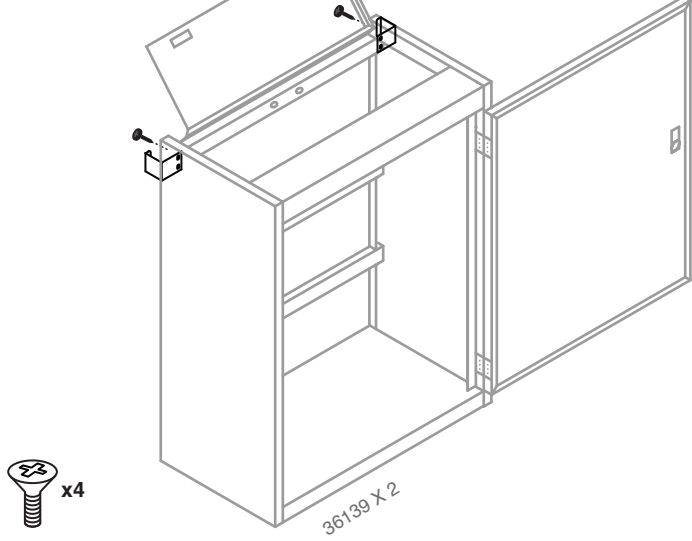

2! LEVEL SHED UNTIL DOORS ALIGN USING ZCOMPPLAS AS SUITABLE

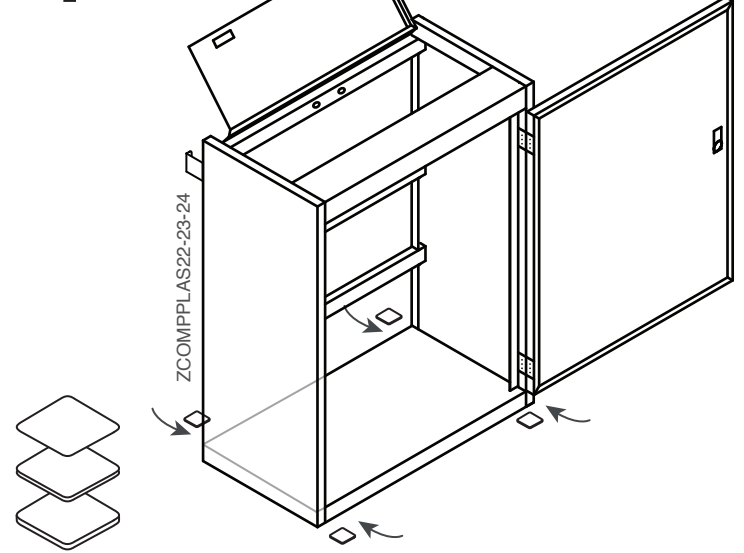

3

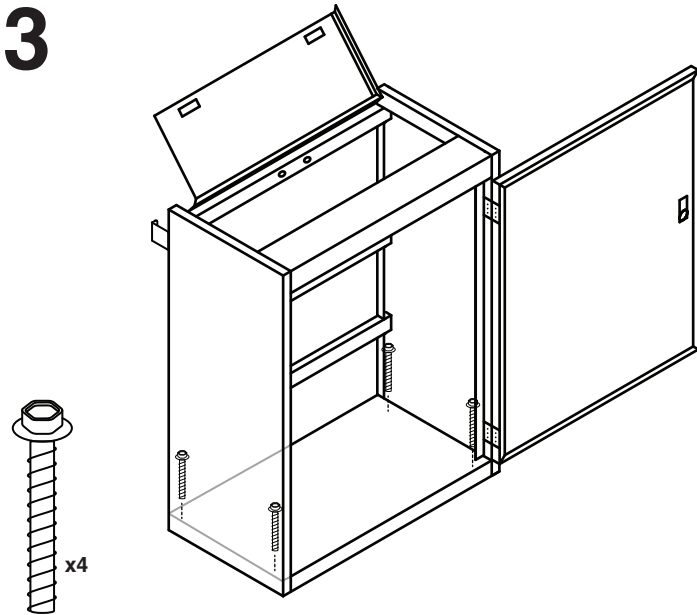

DOOR HANDLING

